

SWEEPER

SR 1100 P/B SR 1200 P/B

SR 5110 P/B SR 5120 P/B

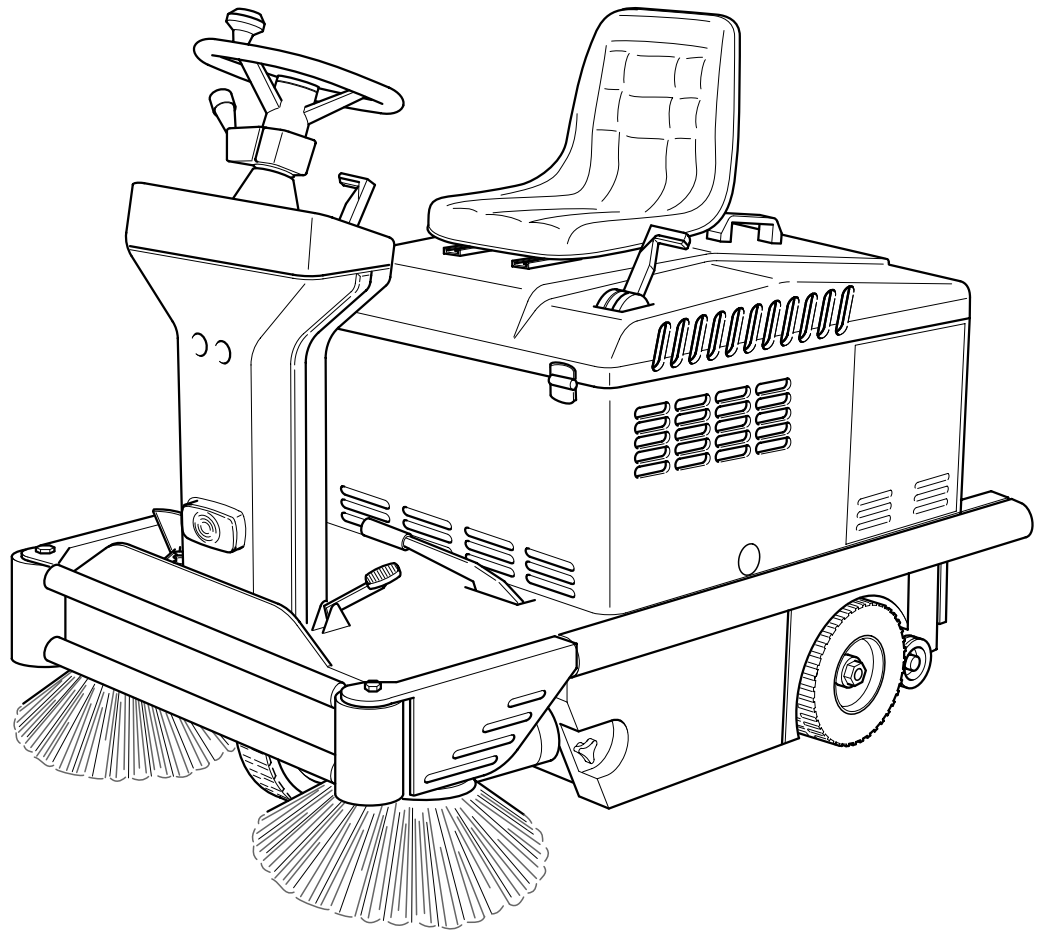

Manual for use and maintenance



**Nilfisk
Advance**

setting standards

FORM No. S31NUK5120(3)2001-04



Model:	Prod. No.:
Serial No.:	Max axel rear:
Power:	Max axel front:
Tot weight:	Noise level:
Tot weight: (w/o battery)	Voltage:

Type G&E Floor cleaning machine.

tuv
GS

CE

MADE IN ITALY

**Nilfisk
Advance**
setting standards

Nilfisk-Advance Italia
Località Novella terza
26862 Guardamiglio (Italia)

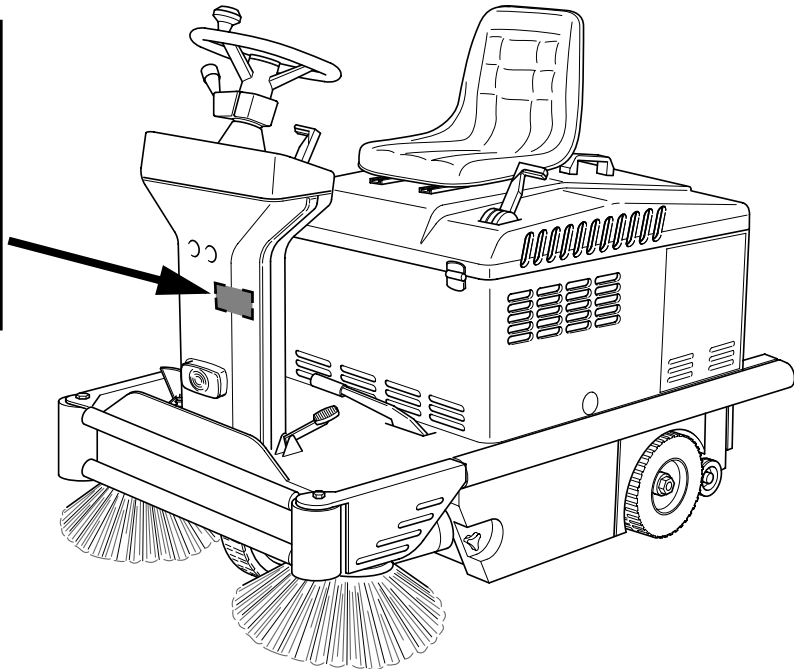

INTRODUCTION / GENERAL INFORMATION	1
UNPACKING	2
TECHNICAL DATA	3
DESCRIPTION OF COMMANDS AND CONTROL PANEL	4
PRELIMINARY OPERATIONS	5-7
USE	8-13
USE OF THE WORKING PROGRAMS	9
FURTHER PERFORMANCES OF THE MACHINE	
WITH PETROL ENGINE	13
SIDE BRUSHES ADJUSTMENT AND REPLACEMENT	14
MAIN BRUSH REPLACEMENT	15-16
FILTER CLEANING AND REPLACEMENT	17-18
MAINTENANCE	19-22
BATTERIES: CONTROL AND RECHARGE	19
BRAKES ADJUSTMENT	20
FRONT LAMP REPLACEMENT	20
MAINTENANCE OF THE PETROL ENGINE	21-22
SUMMARY OF MAINTENANCE CONTROLS (battery version)	23
SUMMARY OF MAINTENANCE CONTROLS (petrol version)	24
OPTIONAL ITEMS	25
SAFETY FUNCTIONS AND TROUBLE-SHOOTING	26
SERVICE ADDRESSES	27

This manual will help you get the most from your Nilfisk SR1100 - SR1200. Read it thoroughly before operating the machine. Specifications and details are subject to change without prior notice.

SPARE PARTS AND MAINTENANCE

Repairs, when required, should be performed by Nilfisk-Advance service personnel using Nilfisk-Advance original replacement parts and accessories. Any "left," or "right," indication are always defined with reference to the machine forward movement direction.

When calling Nilfisk-Advance for repair parts or service, please specify the Model and the Serial Number when discussing your machine.

CHANGES AND IMPROVEMENTS

Our company constantly improves its products and reserves the right to make changes and improvements at its discretion without being obliged to apply such benefits to the machine that were previously sold.

NAME PLATE

The Model and the Serial Number of your machine are shown on the Name plate located on the steering column. This information is needed when ordering repair parts for the machines. Use the space below to note the Model and the Serial Number of your machine for future reference.

MODEL _____

SERIAL NUMBER _____

GENERAL SAFETY RULES

Carefully follow the rules described below to avoid injury to the operator and damage to the machine.

Carefully read the labels on the machine, do not cover them for any reason and replace them immediately if they become worn or damaged.

- The machine storage temperature range should be between 32°F and 104°F
- The machine working temperature is from +32°F to +104°F
- Humidity range should be between 30% and 95%.
- Do not use the machine in an explosive atmosphere environment
- Do not use the machine as a transport vehicle.
- Do not allow the brushes to operate while the machine is stationary to avoid damaging the floor.
- In case of fire, use a powder extinguisher.
- Do not bump into shelves or scaffolding where there is a risk of falling objects.
- Adjust the operating speed to the floor conditions.
- Do not exceed the declared slope limit to avoid an unstable condition.
- When the machine is parked, remove the key and engage the parking brake.
- When machine-operating malfunction occur, make sure that they are not caused by a lack of routine maintenance. If not, request assistance from the service centre.
- If parts must be replaced, request ORIGINAL spare parts from a dealer or Authorised Retailer.
- Before any maintenance operations, disconnect the electric power supply from the batteries.
- Do not remove guards which require the use of tools to be disassembled.
- Do not wash the machine with pressurised water, or with corrosive substances.
- A service centre should inspect the machine every 200 hours of operation.
- The machine must be disposed of properly, because of the presence of toxic-harmful materials (battery acid, oil, etc.) which are subject to standards that require disposal in special centres.
- The machine will not generate damaging vibration.

SAFETY- ACCIDENT PREVENTION

No accident prevention program is effective without the complete co-operation of the person directly responsible for operating the machine. Most of the accidents that may occur in a company, on the job or during transfers are caused by not-observing fundamental safety rules. A careful and cautious user is the best guarantee against accidents and is more effective than any type of prevention program. While using the machine pay attention to your surroundings and people nearby, especially to children.

SAVE THESE INSTRUCTIONS !!

Please check that the following items are supplied with the machine:

1- envelope with cables for batteries and connector for battery-charger.

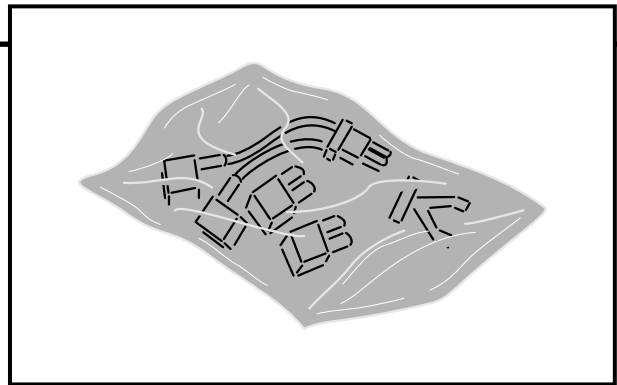

2- technical documents (Spare Parts Catalogue, Manual for Use and Maintenance and - for the petrol version only - Use and Maintenance Manual of the engine).

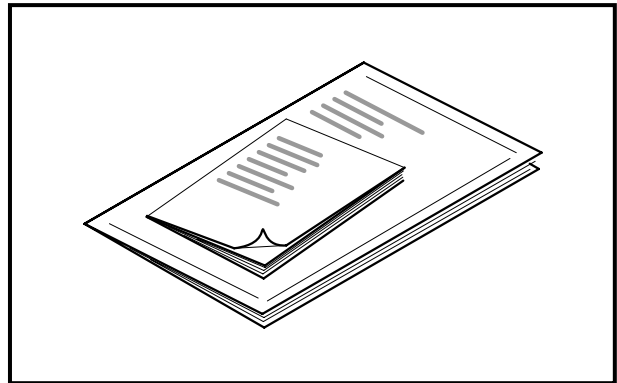

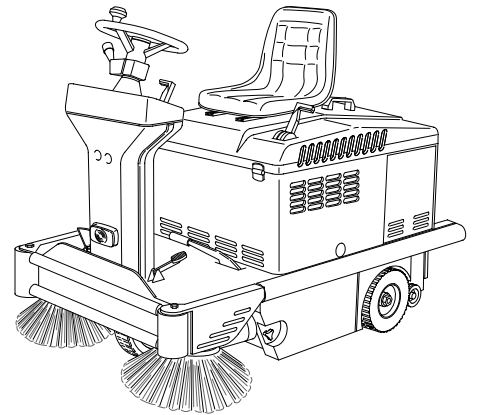

VERSION	SR 1100B - SR 5110B	SR 1100P - SR 5110P	SR 1200B - SR 5120B	SR 1200P - SR 5120P
Voltage	24V	24V	24V	24V
Engine model	/	Honda G150 -K1 144 cc	/	Honda G150 -K1 144 cc
Nominal Power at 3600 RPM	/	3,8 Hp - 2,8 Kw	/	3,8 Hp - 2,8 Kw
Power at 3200 RPM setting	/	3 Hp - 2,2 Kw	/	3 Hp - 2,2 Kw
Start	/	Electric	/	Electric
Drive electric motor	450W - 120 RPM	450W - 120 RPM	550W - 330 RPM	550W - 330 RPM
Main brush electrical motor	500W - 1600 RPM	500W - 1600 RPM	500W - 1600 RPM	500W - 1600 RPM
Suction electric motor	200W - 3300 RPM	200W - 3300 RPM	200W - 3300 RPM	200W - 3300 RPM
Side brush electric motor	60W - 120 RPM	60W - 120 RPM	90W - 120 RPM	90W - 120 RPM
Forward speed	max 7 km/h	max 7 km/h	max 9 km/h	max 9 km/h
Reverse speed	max 3,5 km/h	max 3,5 km/h	max 4 km/h	max 4 km/h
Max slope	20%	20%	20%	20%
Main brush	Ø 300 mm x 700 mm	Ø 300 mm x 700 mm	Ø 300 mm x 800 mm	Ø 300 mm x 800 mm
Side brush	Ø 430 mm	Ø 430 mm	Ø 460 mm	Ø 460 mm
Cleaning width with 1 side brush	900 mm	900 mm	1050 mm	1050 mm
Cleaning width with 2 side brushes	1100 mm	1100 mm	1250 mm	1250 mm
Front wheel (NR 1)	Ø 250 mm	Ø 250 mm	Ø 250 mm	Ø 250 mm
Rear drive wheels (NR 2)	Ø 250 mm	Ø 250 mm	Ø 250 mm	Ø 250 mm
Container capacity	70 lt	70 lt	100 lt	100 lt
Panel filter	2,95 m ²	2,95 m ²	2,95 m ²	2,95 m ²
Electric filter shaker	90W - 6000 RPM	90W - 6000 RPM	90W - 6000 RPM	90W - 6000 RPM
Machine length	1376 mm	1376 mm	1489 mm	1489 mm
Width	910 mm	910 mm	1020 mm	1020 mm
Height	1193 mm	1193 mm	1251 mm	1251 mm
Weight (without batteries)	240 kg	280 kg	300 kg	350 kg
Fuel tank capacity	/	2,5 lt	/	2,5 lt
Engine oil tank capacity	/	0,7 lt	/	0,7 lt

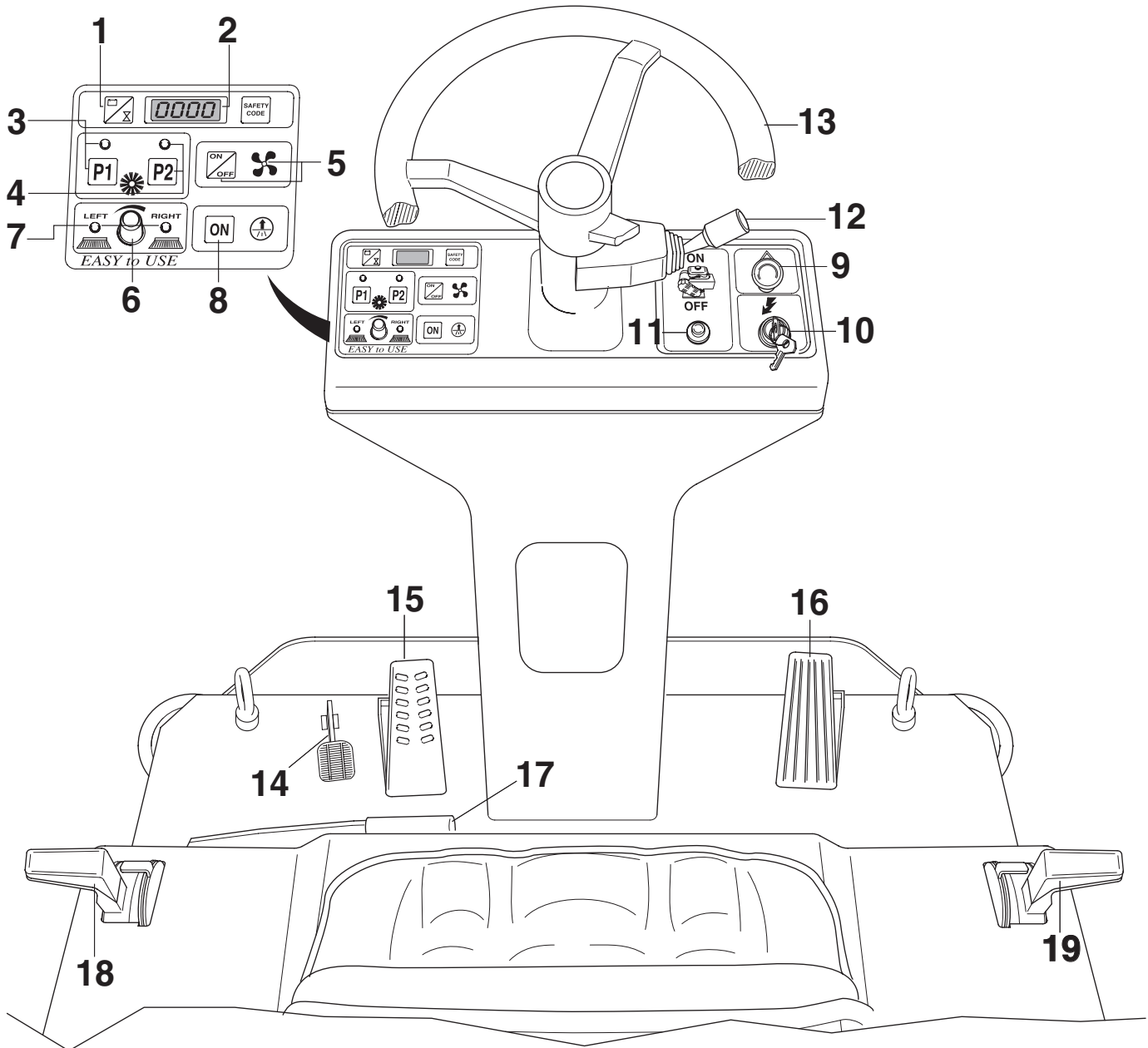

- | | |
|---|---|
| 1- Voltmeter/hourmeter push button | 10- ON/OFF main key switch |
| 2- Display | 11- Start/Stop push button for petrol engine |
| 3- Button for selection/indicator of working program P1 | 12- Selection of forw./reverse speed, light ON/OFF, horn |
| 4- Button for selection/indicator of working program P2 | 13- Steering wheel |
| 5- ON/OFF button and indicator of suction motor | 14- Pedal for flap lifting |
| 6- Knob for the speed adjustment of the side brushes | 15- Brake pedal |
| 7- Indicator of the operation of left/right side brushes | 16- Accelerator |
| 8- ON button of filter-shaker motor | 17- Parking brake lever |
| 9- Emergency stop push button | 18- Lever for left side brush command |
| | 19- Lever for right side brush command |

Both versions of the machine, petrol and battery, require a 24 V battery set.

Depending on the country where the machine is sold three possibilities can occur:

- 1- the battery is supplied with the machine and it is set, complete with acid solution
- 2- the battery is supplied with the machine and it is set, but not complete with acid solution
- 3- the battery is not supplied.

The battery compartment is under the seat: lift the compartment lid, towards the steering wheel, and verify which one of the three possibilities is applied to your machine.

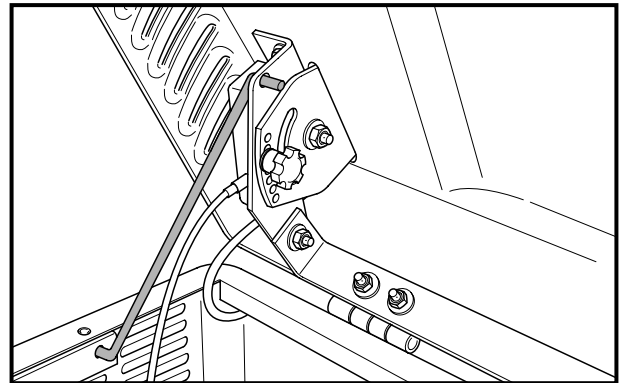

If the batteries are installed open one of the caps of every battery and check if they are filled with electrolyte.

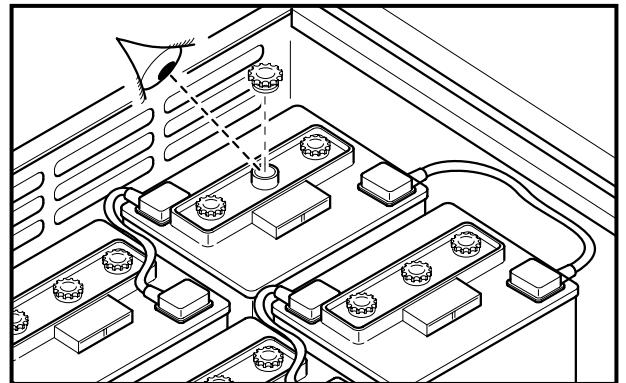

- 1- If the battery is filled:
 - 1a. Check the electrolyte level in every cell and - if necessary- fill up with distilled water.
 - 1b. Proceed with a battery recharge according to the MAINTENANCE paragraph and to the Battery User Manual.

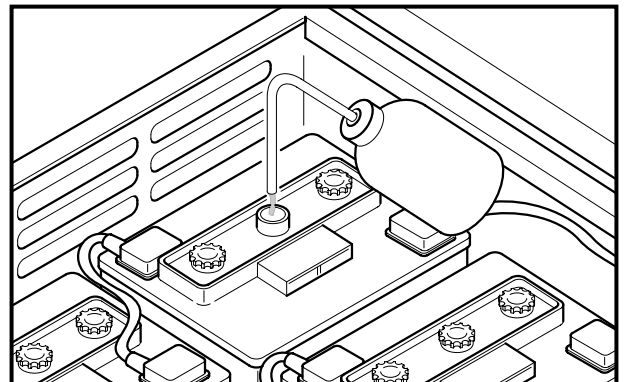

WARNING: before starting the recharge the battery connector must be disconnected from the machine.

After the recharge plug the battery connector to the machine.

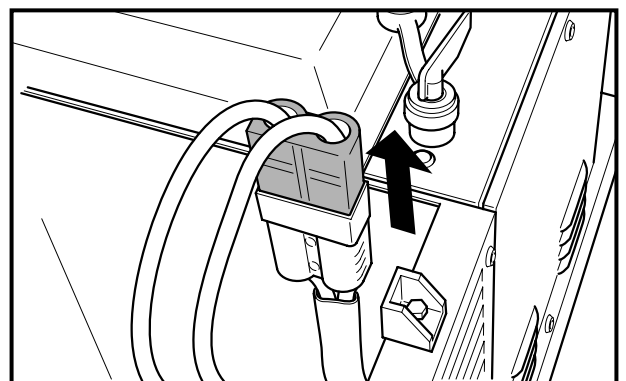

2- If the batteries are installed but not filled with acid solution they must be filled with a solution of sulphuric acid (density between 1,270 Kg and 1,290 Kg at 25°C temperature) according to the instructions specified below and in the Battery User Manual.

BATTERY FILLING UP WITH ACID SOLUTION

Warning: the battery acid is corrosive; if it comes in contact with the skin or eyes rinse thoroughly with water and consult a physician.

The batteries must be filled in a well ventilated area.



Fill every battery cell with acid; the right level is specified in the Battery User Manual.

After one hour fill up with acid, if necessary.

Let batteries rest for a further hour; then proceed with a recharge according to the instructions specified in the Battery User Manual and in the MAINTENANCE paragraph. During the recharge the battery caps must be open.

WARNING: before starting the recharge the battery connector must be disconnected from the machine.

After the recharge close all the cell caps and clean the top of the battery from any acid remains.

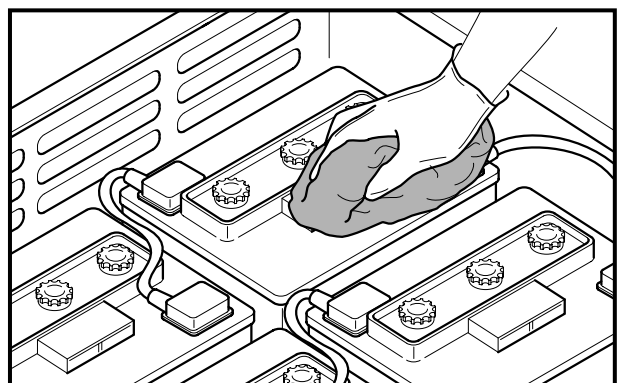
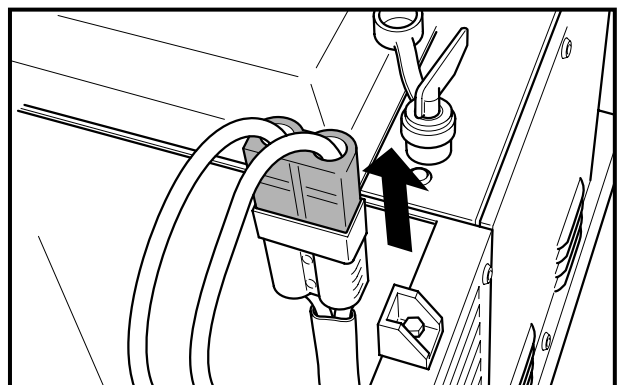
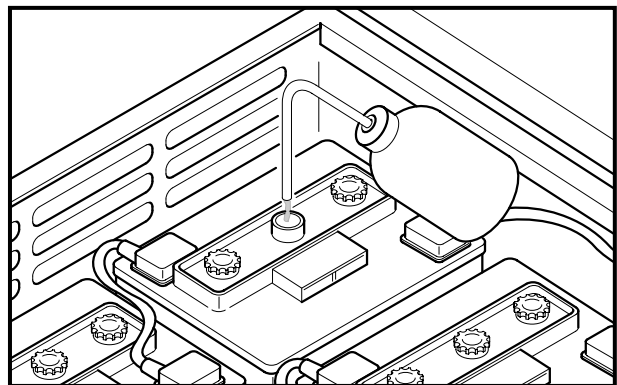

Connect the battery connector to the machine.

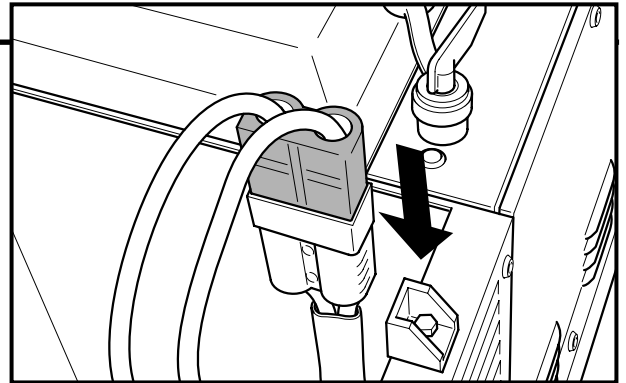

3- If the machine is not equipped with batteries they must be procured and mounted. It is recommended to get the assistance of qualified personnel to choose and set the batteries.

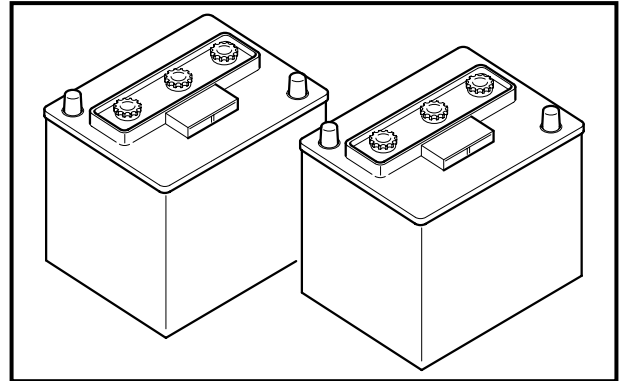

The electric cables supplied with the machine can be used for the connection of the four batteries.

WARNING: before starting the recharge the battery connector must be disconnected from the machine.

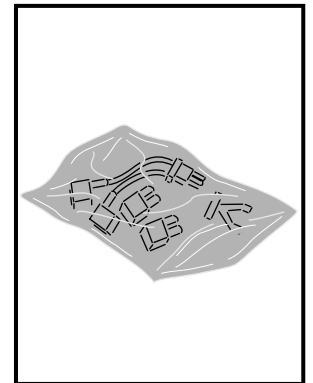
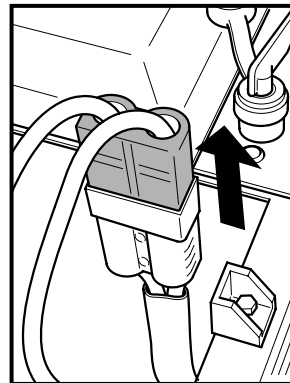

Fill the fuel tank with **UNLEADED PETROL** and close the engine compartment. Check the engine oil level according to what specified in chapter "Maintenance"

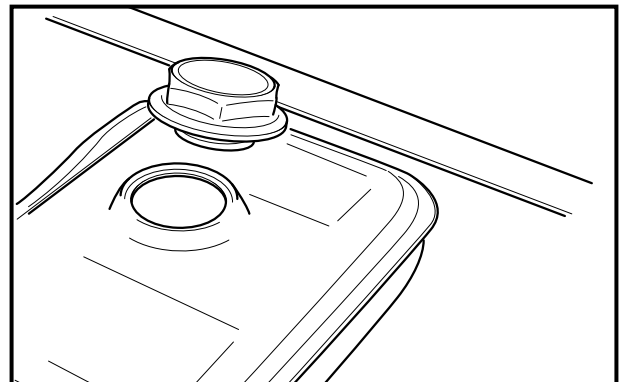

After having set the batteries, climb onto the machine and adjust the seat to find the most comfortable position.

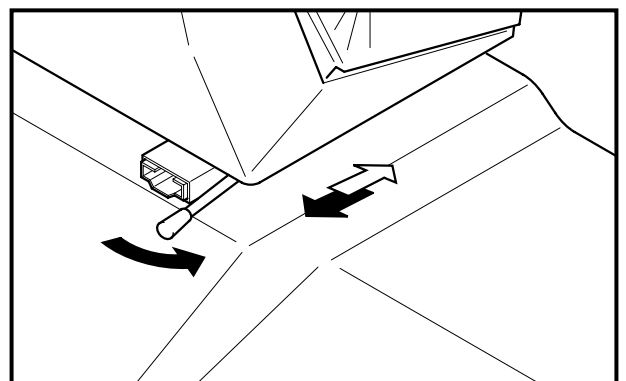

Now the machine is ready to be used.

Insert the ignition key into the panel and turn it clockwise: the display will show all zeros and after about three seconds the battery voltage will appear.
Note: the temporary lighting of the two side brush indicators and the short sound from the reverse speed acoustic indicator are to be considered a normal behaviour.

Wait not less than three seconds before restarting the machine after switching Off.

Check the charge status of the batteries on the display.
 Six different data/functions can be shown on the display.

The six functions are described in the following table.

Displayed datum/function	Display reading
1. Voltmeter: the battery voltage is normally shown on the display. A block function will be activated in case of battery undervoltage: when battery voltage will be about 20V all machine functions will stop, except traction; in this case the display will show 0205; proceed then with a battery recharge (see Maintenance paragraph)	Normally fixed. (battery voltage) Flashing when 0205 appears.
2. & 3. Hourmeter: to read the machine working time - in hours - press once the yellow display button. By pressing the button a second time the working minutes will appear. Just waiting ten seconds the display will show the battery voltage again	Fixed
4. Total swept surface (m²): the displayed value will increase each 1000 m ²	Fixed
5. Daily swept surface (m²): the displayed value will increase each 10 m ²	Fixed
6. Productivity: sweeping rate m ² /hour: it depends on the instantaneous machine working speed	Flashing

Notes:

- to pass to the next function press the yellow display button once, 10 seconds after choosing one of the possible data/functions
- the display will return automatically to the battery voltage from every function
- data 2 and 3 will increase just using the traction function (accelerator pedal)
- data 4, 5 and 6 will increase only if main broom is turning AND traction function is used
- when datum 5 is displayed you can reset it just by keeping the yellow display button pressed 5 seconds.
- If the batteries are charged enough, now it is possible to start the job (in battery mode).

If the machine is equipped with the gasoline engine, proceed with the start of the engine itself.

START/STOP OF THE PETROL ENGINE

To start the gasoline engine press the red button shown in the figure; to stop the engine press the same button again.

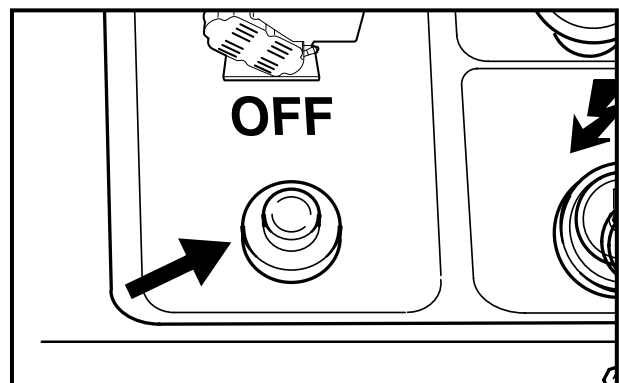
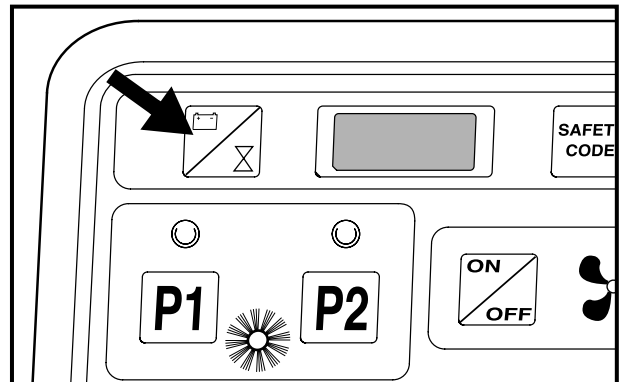
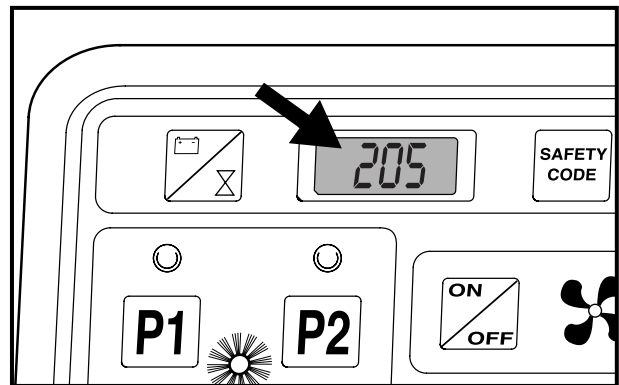
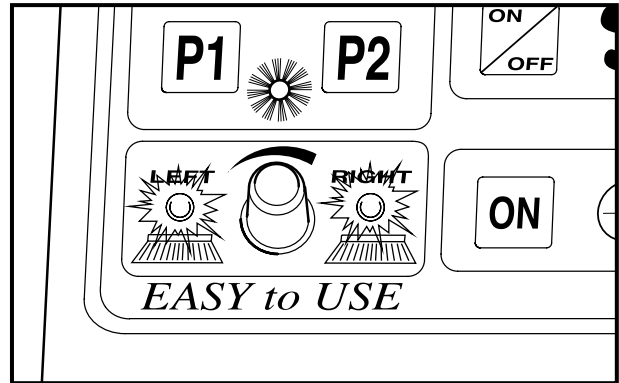
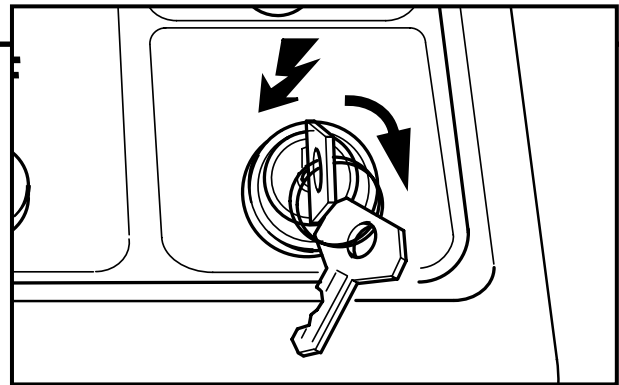

USE OF THE WORKING PROGRAMS

Once the machine has been turned on and eventually after starting the petrol engine, choose one of the two working programs P1 and P2 according to your cleaning need and press the relevant button:

P1 is the “light cleaning program” (for internal environment, i.e. smooth floor, moquette, small debris etc.)

P2 is the “hard cleaning program” (for external environment, i.e. asphalt, uneven floor, big debris etc.).

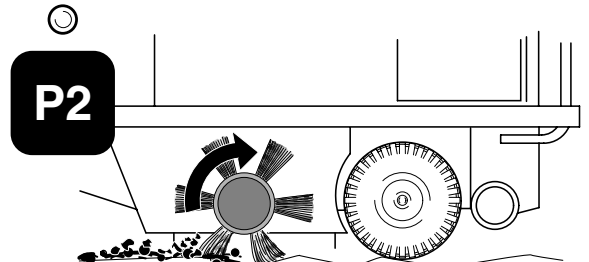
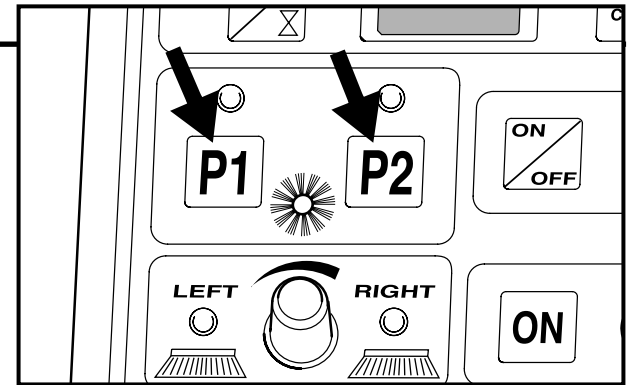
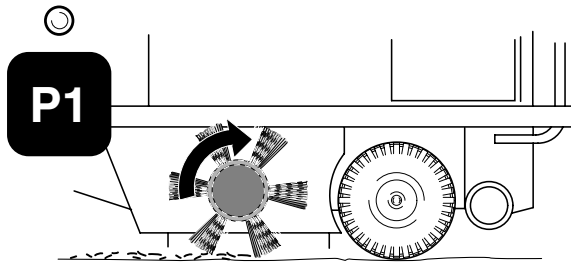

After having pressed the preferred button the relevant light indicator will turn on, together with the suction motor indicator.

The temporary activation of the main brush and suction electric motors will also occur; (the relevant light indicators will flash).

Note: the working parameters of programs **P1** and **P2** are pre-set by the manufacturer of the machine: if you want to change the pre-set values call the customer service personnel of your supplier.

Lower the side brush/es by pressing the top of the relevant lever and moving it forward.

Note: on the control panel the corresponding light indicators will turn on.

To lift the side brush/es press the top of the levers and move them backwards.

Note: the side brush/es, the main brush and the suction fan will start automatically when the accelerator pedal will be pressed (AUTO POWER-ON).

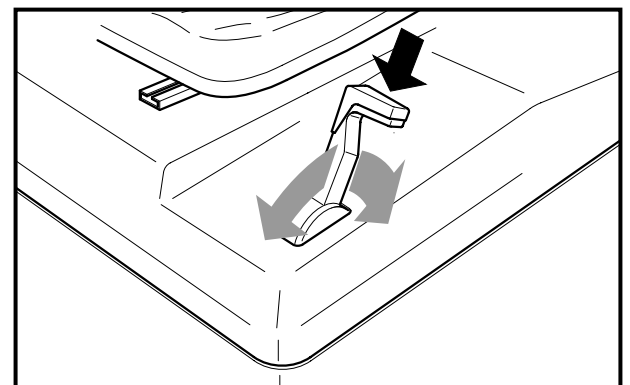
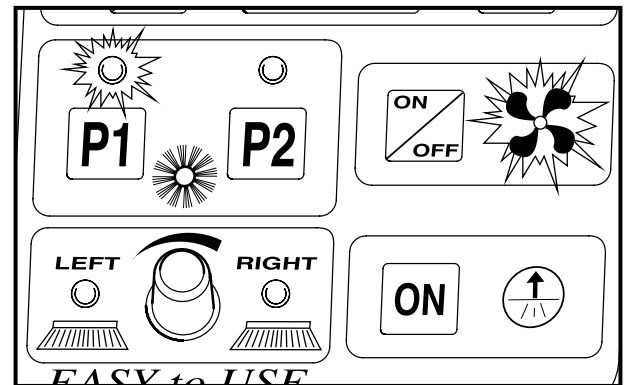

It is possible to adjust the side brush/es turning speed by means of the dedicated knob.

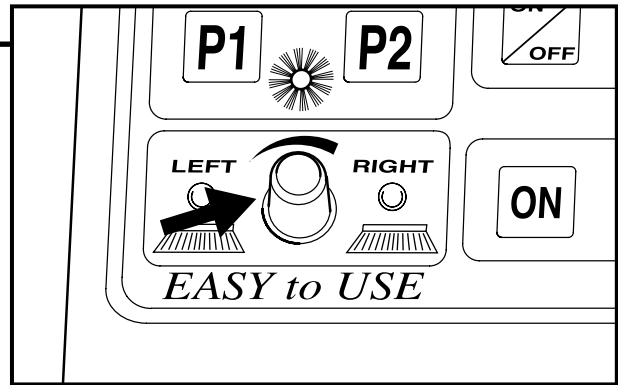

Select the forward speed by means of the command lever.

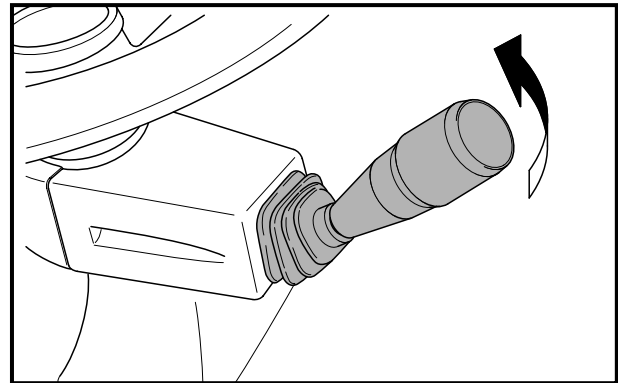

Press the accelerator pedal to start the job.

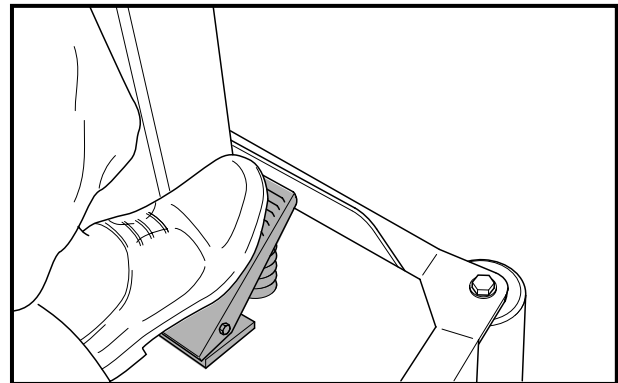

Note: by releasing the accelerator pedal (or setting the command lever to the neutral position) the automatic switch off of all functions will occur within 8 seconds (Auto Power Off); the light indicators of the selected working program and of the suction fan will start flashing. The automatic restart of all functions will automatically occur as soon as the accelerator pedal will be pushed again (Auto Power ON).
 In order to enable the selection of a different working program first disable the previously selected one.

When it is necessary to sweep on a wet floor stop the suction fan pressing the relevant button, in order to prevent the damage of the paper panel filter.

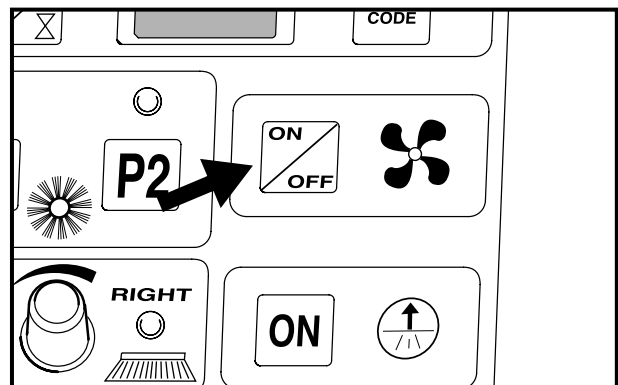

In order to get an efficient cleaning function the panel filter must always be clean.

Press the filter-shaker button, even if the machine is working.

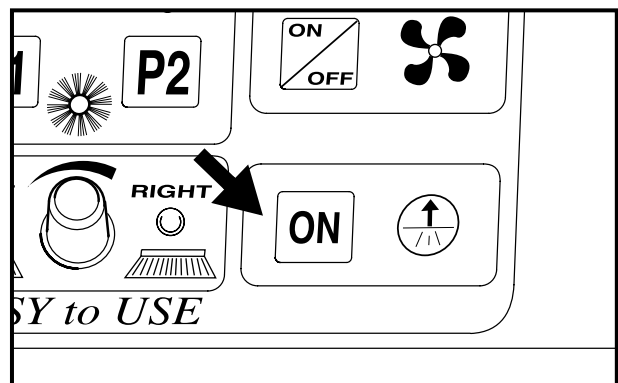

This operation must be repeated every 10 to 15 minutes, depending on the kind of rubbish to be swept; before emptying the dirt container and, in any case, at the end of the work.

To collect light and bulky debris lift the front flap using the left pedal (do not press the pedal down for a long time, not to reduce the suction capability of the machine).

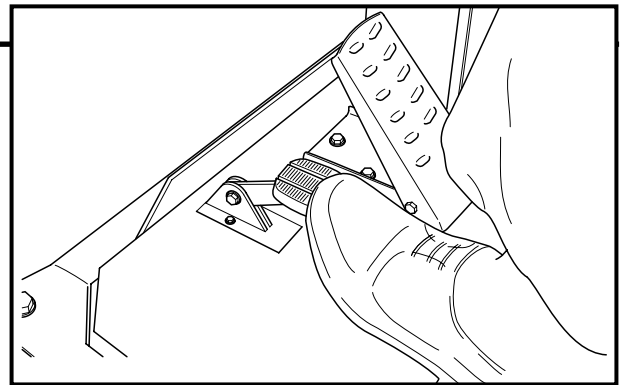

The machine gets an automatic braking function when the accelerator pedal is released; when necessary the service brake can also be used (see the figure).

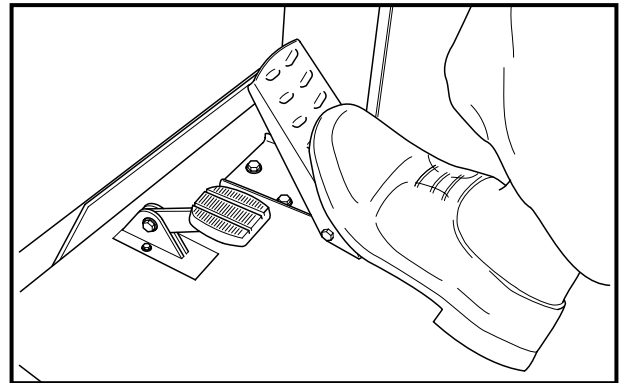

When driving in reverse gear an intermittent acoustic signal will be heard and all the functions will remain active.

The figure shows the functions of the command lever:

- 1- forward gear
- 2- reverse gear
- 3- horn
- 4- front light On/Off.

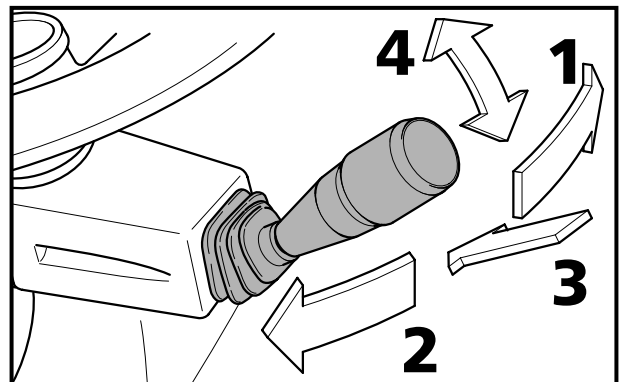

The machine is equipped with an emergency stop button; by pressing this button (red light On) a sudden stop of the machine will occur and all functions will turn off, the petrol engine too.

To restart the machine turn the red button clockwise (according to the arrow shown on the button itself).

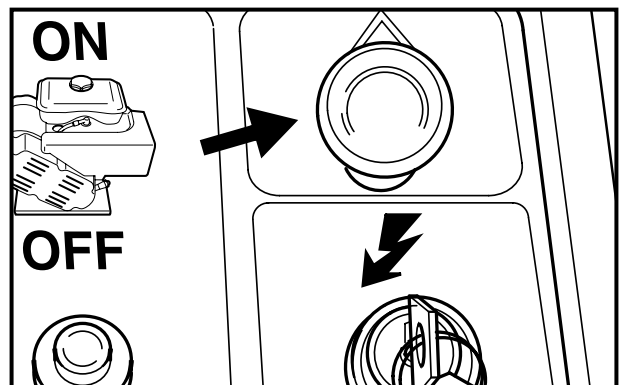

To restart the normal operation re-select one of the two working programs **P1** or **P2**.

A safety device is located inside the operator seat: the drive function - either forward or reverse - is disabled as soon as the operator will stand up or leave the seat.

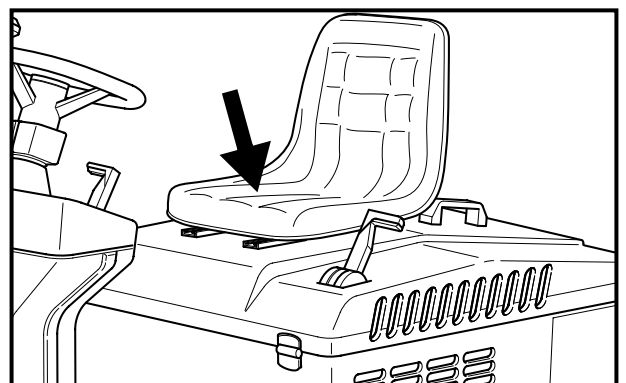

At the end of the job turn off the selected working program (**P1** or **P2**) and switch the petrol engine off by pressing the button shown in the figure.

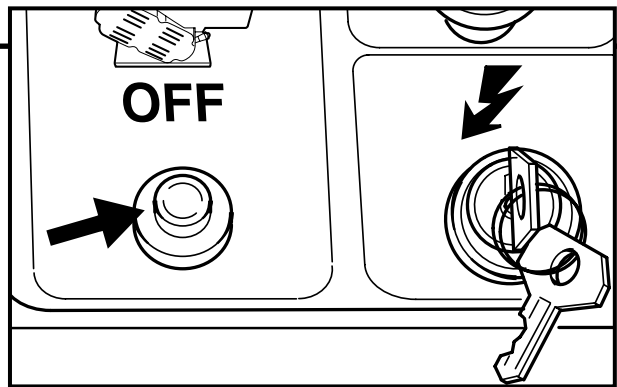

Before leaving the machine make sure that the side brushes are lifted, the parking brake engaged and the master key in the OFF position. (counter clockwise)

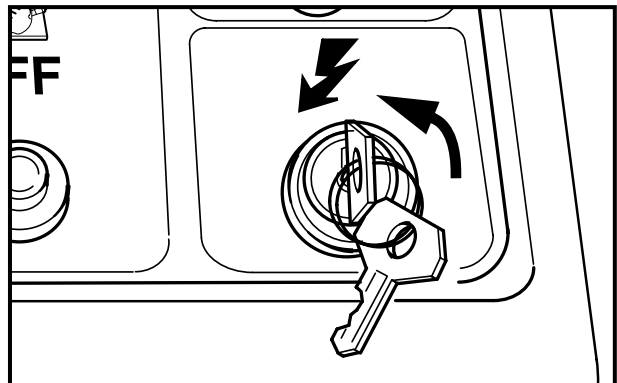

At the end of the job or whenever it is necessary empty the rear dirt container.

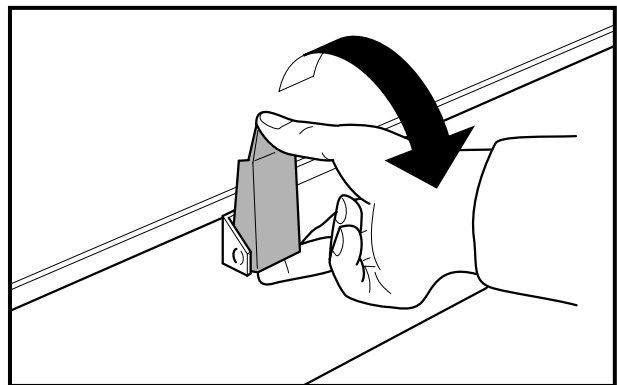

In the event that the machine must be pushed when switched Off turn the proper red key counter-clockwise (see the figure), in order to disengage the electric drive motor and disable the self-breaking function. Turn and eventually remove the red key that can be seen after lifting the lid of the battery compartment.

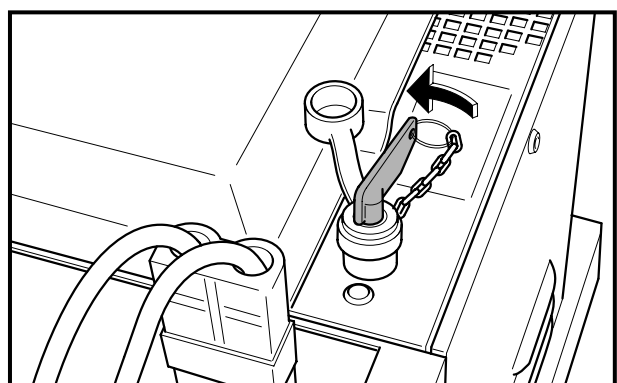
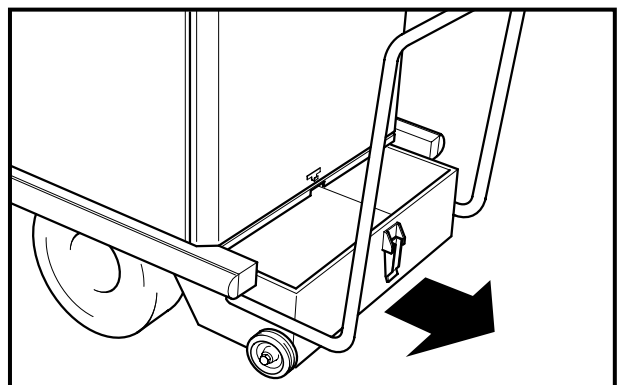

FURTHER PERFORMANCES OF THE MACHINE WITH PETROL ENGINE

The machine equipped with the petrol engine is able to work with full performance even if the petrol engine is turned Off; this could occur just because the machine run out of the fuel or when it is necessary to work in a closed environment.

In this case the available working time will depend on the capacity (amper.hours) of the batteries installed on the machine; on the intensity of the selected working program; on the charge status of the batteries.

On this machine, in order to guarantee the reliability of the batteries, two safety features are envisaged:

1- protection against the deep discharge of the battery: when the battery voltage drops down to about 20 Volt the automatic stop of all function will occur - except the traction function. When it is in this condition, it is necessary to proceed with the recharge of the battery or to start the petrol engine.

2- Protection against the excessive recharge. If the battery voltage will be over 29 Volt the automatic stop of the petrol engine will occur.; in any case the machine will still be able to operate only with batteries. The petrol engine can be restarted when the battery voltage will be low enough (at about 24 Volt).

SIDE BRUSHES ADJUSTMENT AND REPLACEMENT

S31NUK5120(3)2001-04

Warning: the following operations must be done with the machine in Off condition and master key out, on a flat floor.

When the side brush is worn its height must be adjusted.

Loosen the knob. Turn the adjusting disk and move its position of one hole. And tighten the knob.

To check the adjustment of the brush start it and verify that the contact with the floor is as shown in the figure. If necessary repeat the adjustment sequence.

When the brush is remarkably worn out, it is necessary to replace it. Just press the two tabs inwards and remove the brush. Reinstall the new brush by carrying out the reverse operation; apply a light pressure to the brush with your hands.

Note: when the brush is replaced set the adjusting devices to their original position (corresponding to brush new, with no wear).

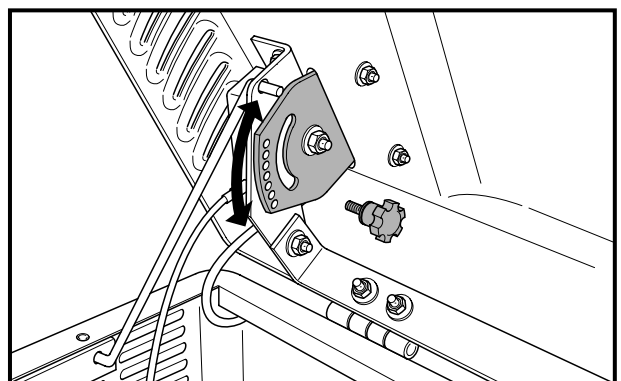
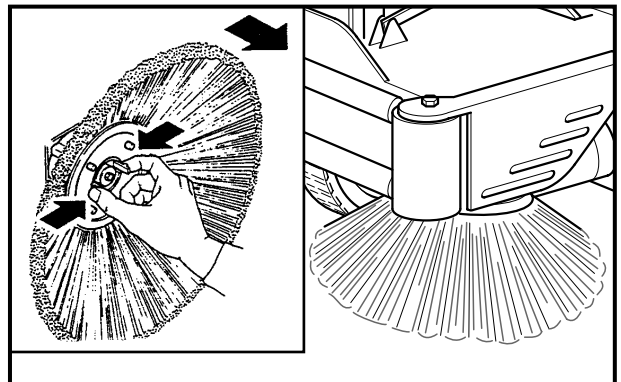
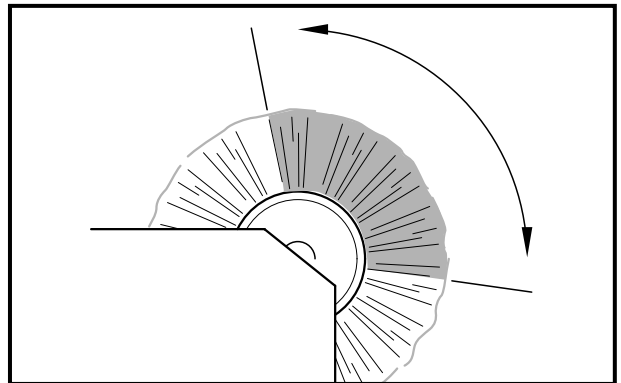
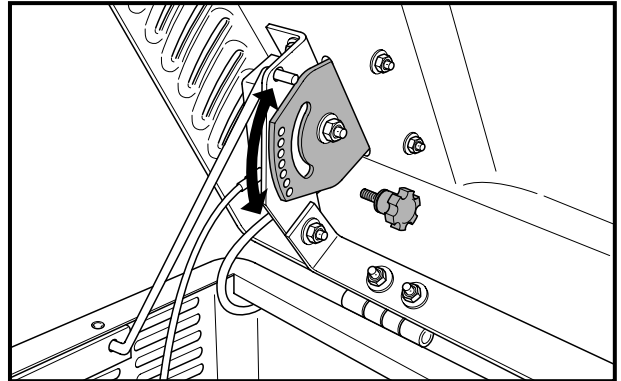
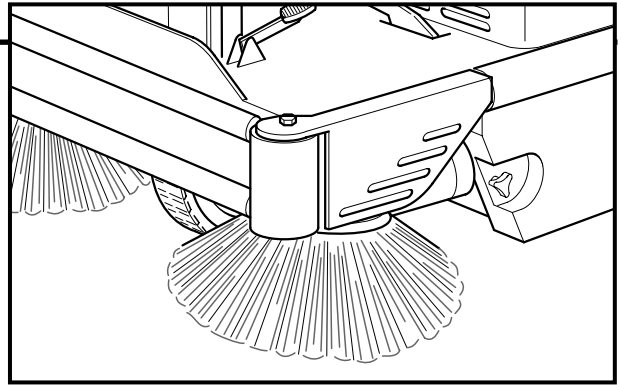

Warning: the following operations must be done with the machine in Off condition and master key out.

This machine is equipped with an automatic control of the main brush pressure; this also means that the position of the main brush is automatically adjusted (no need of manual adjustment).

The complete wear out of the main brush - and therefore the need to replace it - is notified with code 800 on the display.

Please meet the following procedure for the main brush replacement.

Open the side door on the right side of the machine, unscrewing the knob shown in the figure.

Remove the three knobs used to fix the lid of the main brush compartment.

Remove the lid.

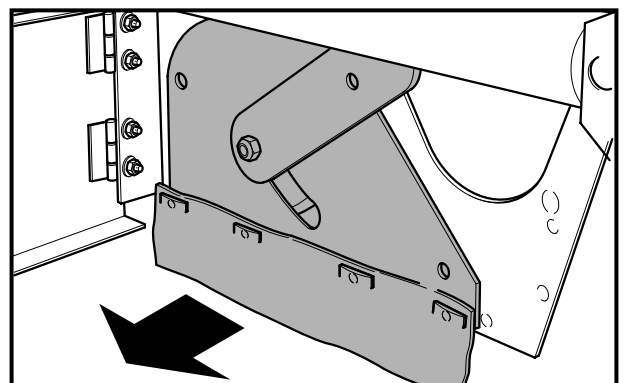
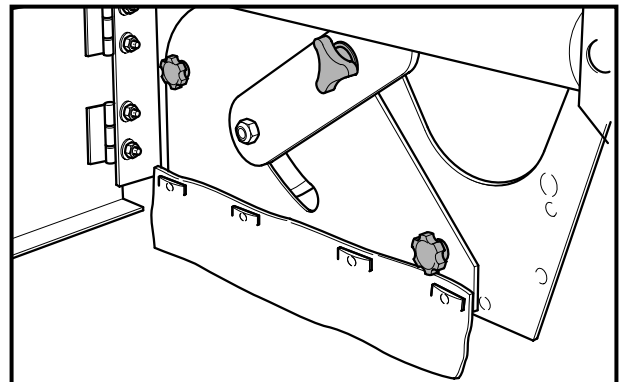
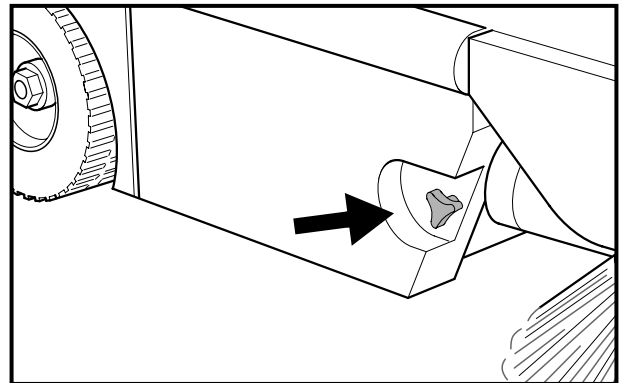
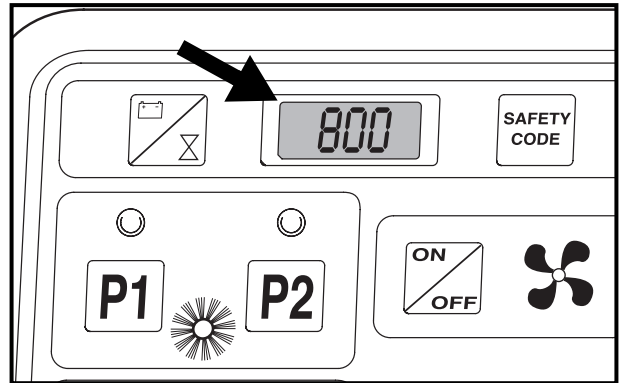
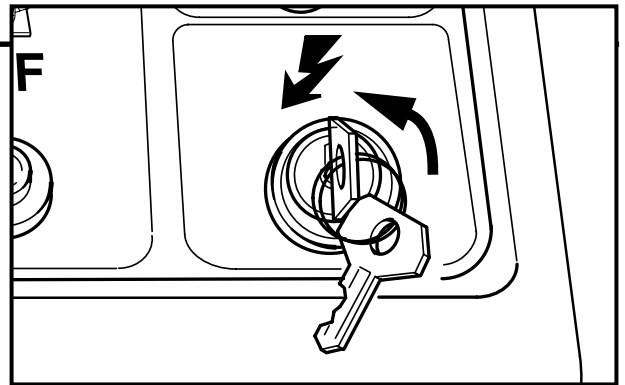

Remove the worn out brush.

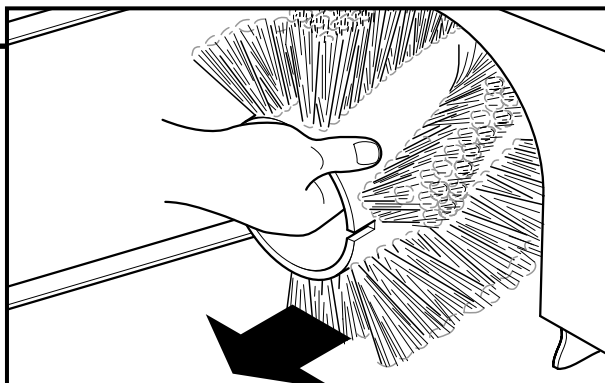

Fit the new brush in its compartment, paying attention to the engagement of the plastic adapter with the hub on the opposite side of the compartment.

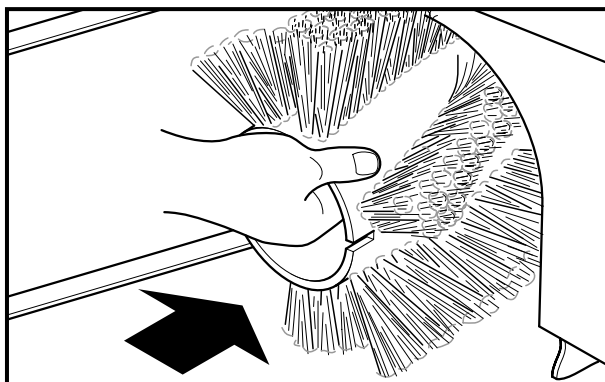

Fit the lid of the main brush compartment using the three knobs previously removed.

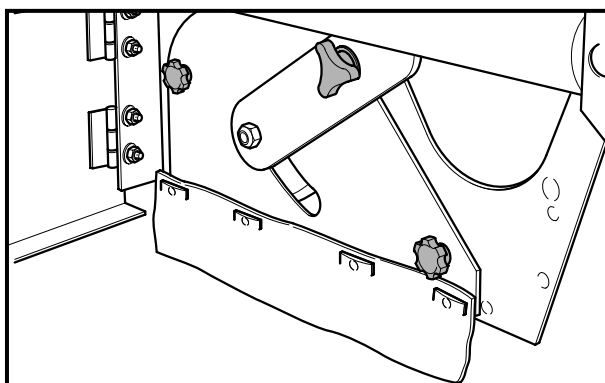

The panel filter requires a regular cleaning.

Lift the lid.

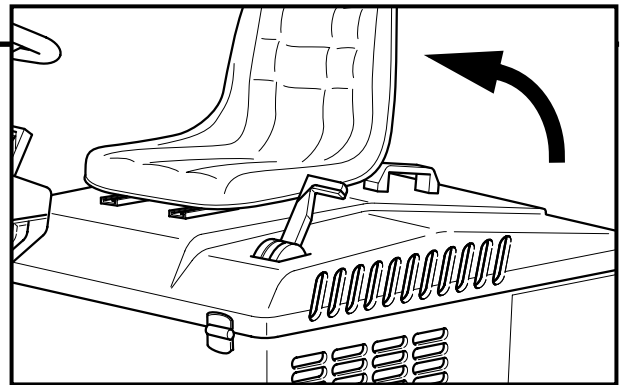

Remove the lid of the filter compartment.

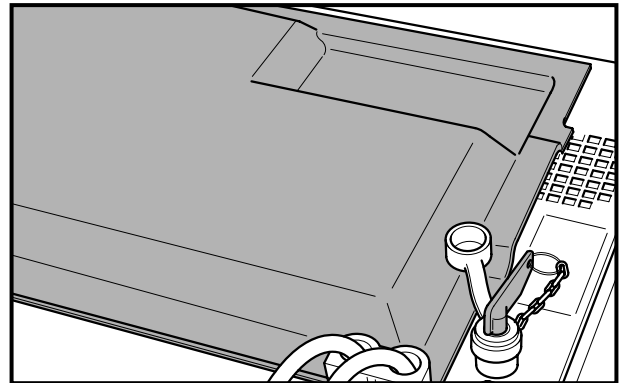

Disconnect the electric cable of the filter-shaker motor (the machine must first be switched off and the key out).

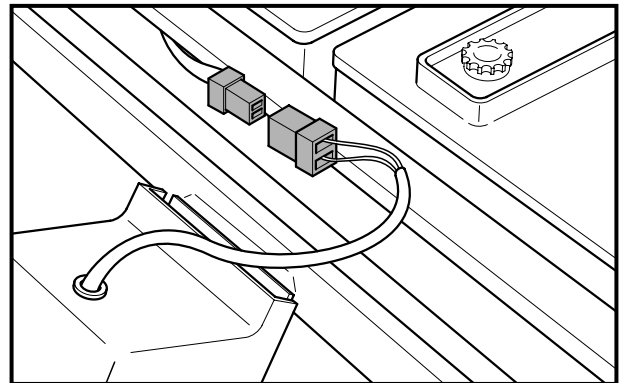

Loosen the two screws with butterfly head on the two sides of the metal frame fixing the panel filter; it is not necessary to remove the screws completely.

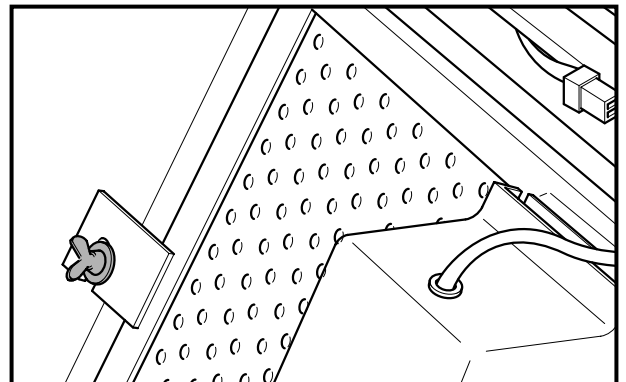

Remove the metal frame and take the panel filter out.

Clean the filter shaking, blowing it with compressed air - pressure not higher than 6 bar - from the side where the metal protection net is mounted, to avoid damaging to the paper.

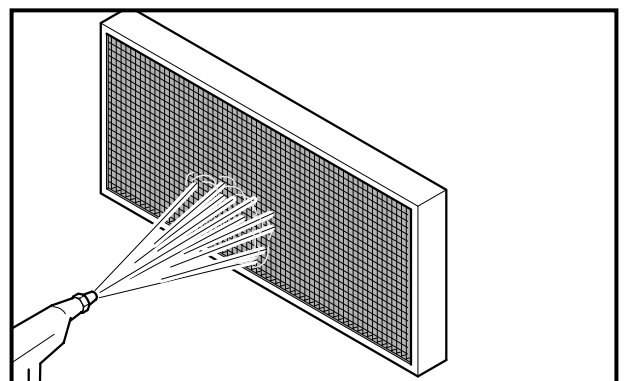

After cleaning, fit the filter and the relevant fixing frame.

Tighten the two screws with butterfly head and reconnect the filter shaker electric cable.

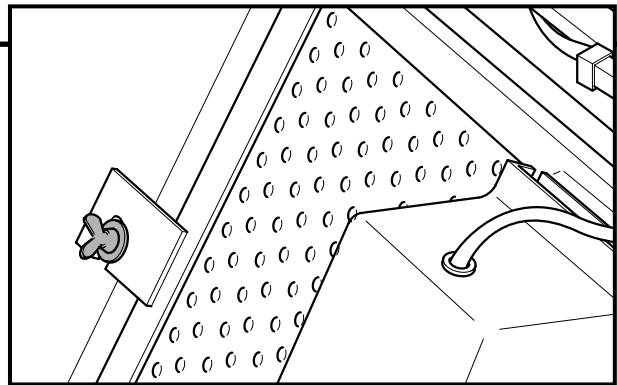

If the filter is damaged or can not be properly cleaned replace it with a new one.

Ask to your supplier for the new spare parts list.

Polyester panel filters are also available.

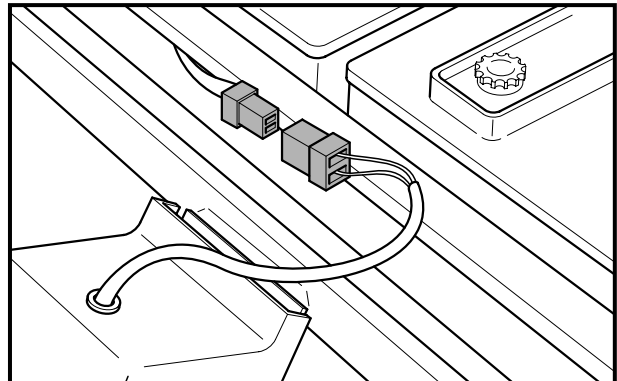

BATTERIES: CONTROL AND RECHARGE

Make a frequent check of the electrolyte level inside every battery cell. The battery compartment is under the operator seat; lift the lid and open the caps of all the battery cells: when necessary fill up the cells with distilled water.

The proper electrolyte level is specified in the Manual for use and maintenance of the battery.

Warning: On the version with petrol engine the battery level check must be done every week.

After filling close all the cell caps and clean the top of the battery from any acid remains.

Warning: the battery acid is corrosive; if it comes in contact with the skin or eyes rinse thoroughly with water and consult a physician.

When necessary proceed with a recharge of the battery according to the following instructions and taking also into account what is specified in the Battery User Manual:

- switch the machine Off and remove the master key.

Warning: before starting the recharge the battery connector must be disconnected from the machine.

- the recharge must be done in a well ventilated area
- open all the cell caps
- connect the battery connector to the battery charger connector
- connect the battery charger cable to the mains (please check that the voltage and frequency of the mains correspond to the data of the charger)

At the end of the recharge disconnect the battery from the charger and fit the battery connector to the machine. Close all the cell caps and clean the top of the battery from any acid remains.

Note: in any case refer to the instructions specified in the Battery Use Manual.

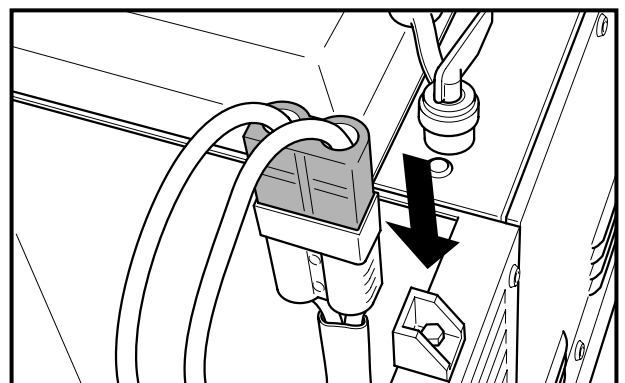
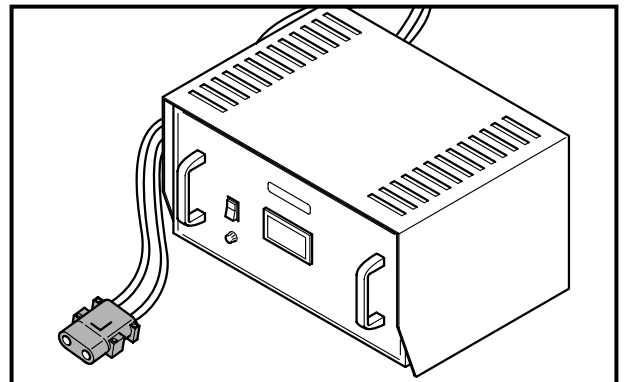
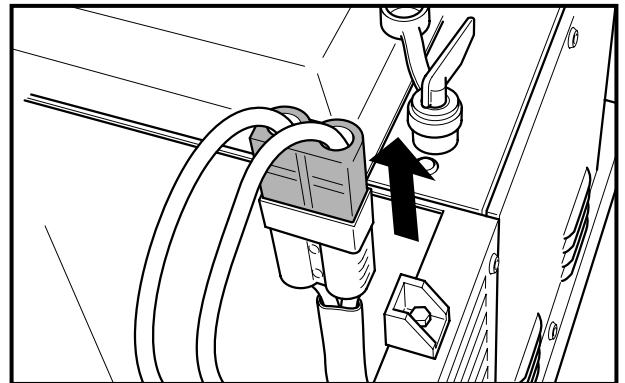
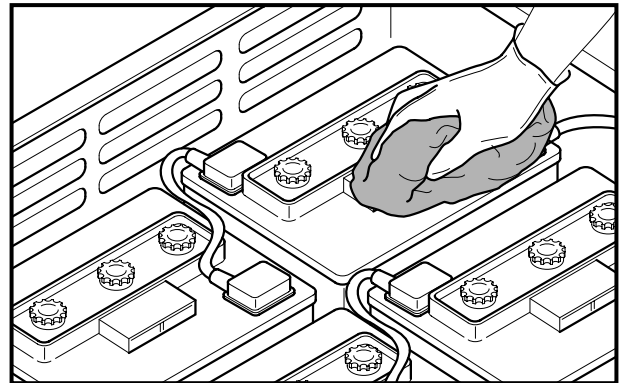
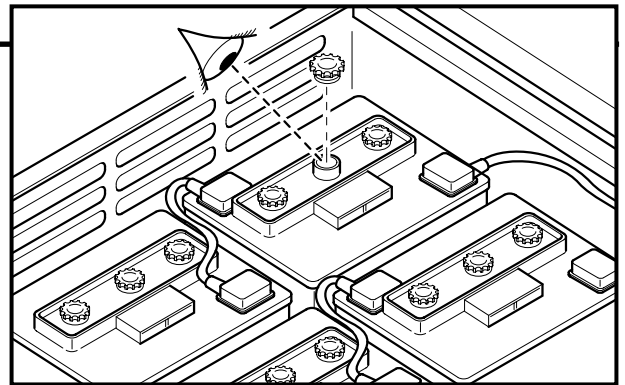

BRAKES ADJUSTMENT

When the pedal brake and/or the parking brake reach a low efficiency operation some adjustments can be done on the front wheel (models SR 1100 e SR 5110):

- loosen the locking nut **A**
- turn adjuster **B**
- tighten locking nut **A**.

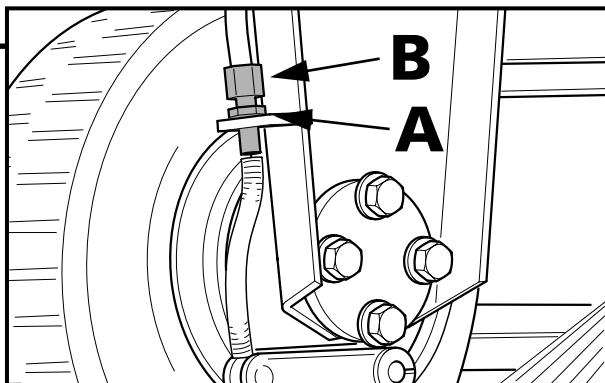

On models SR 1200 and SR 5120 the two brakes on the rear wheels can also be adjusted, by means of the regulating devices located under the foot board (under the brake pedal).

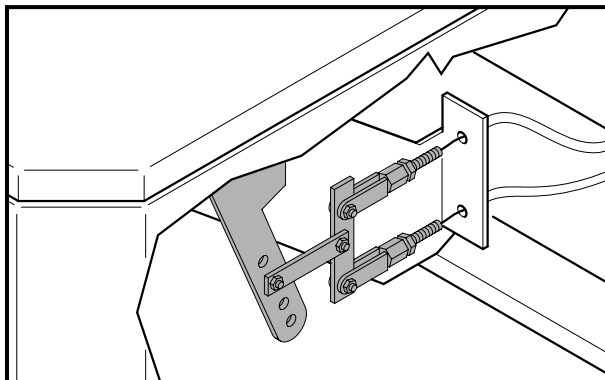

FRONT LAMP REPLACEMENT

In order to replace the front lamp:

- remove the transparent cover

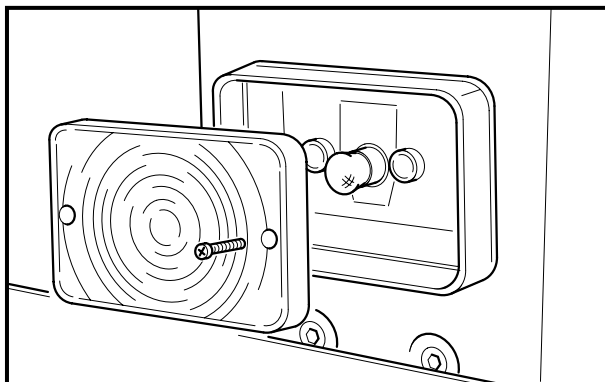

- push the lamp and turn it counter-clockwise to remove it

- replace the lamp paying attention to the volt and watt ratings

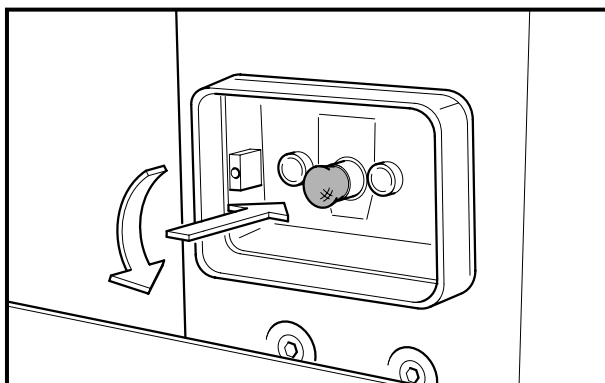

- fit the transparent cover.

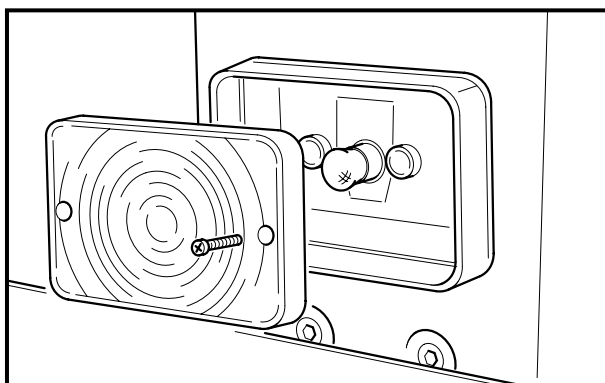

**MAINTENANCE OF THE PETROL ENGINE
(HONDA)**

First: read thoroughly the Use and Maintenance Manual of the engine.
Here below some recommendations are pointed out.

Check the engine oil level at each working session; for possible fill up read the oil type specified on the engine Manual

Warning: the engine oil must be replaced the first time after 20 working hours or, in any case, not later than one month since the receipt of the machine. Afterwards it must be replaced every 100 hours or not later than 8 months since the last replacement.

The procedure for the replacement of the engine oil is specified here below.

Remove the side panel from the machine.

Unhook the engine oil emptying hose.

Slip off the engine oil level check rod.

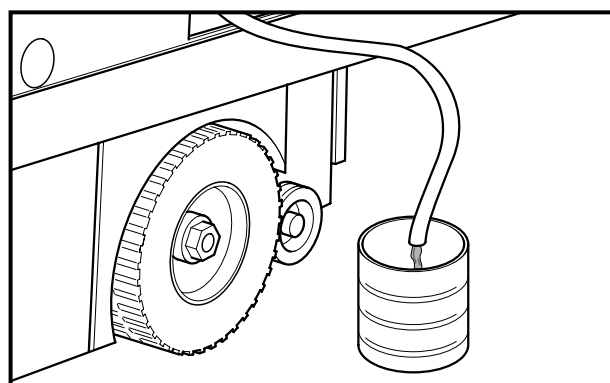
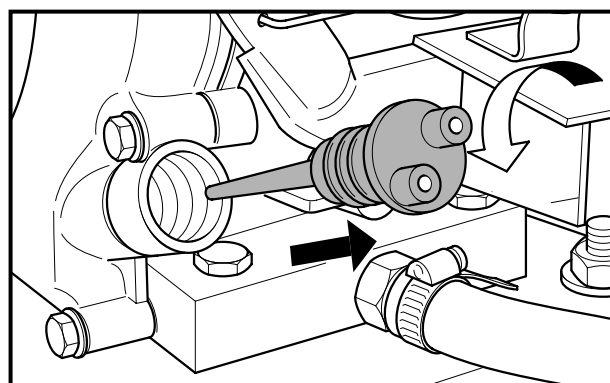
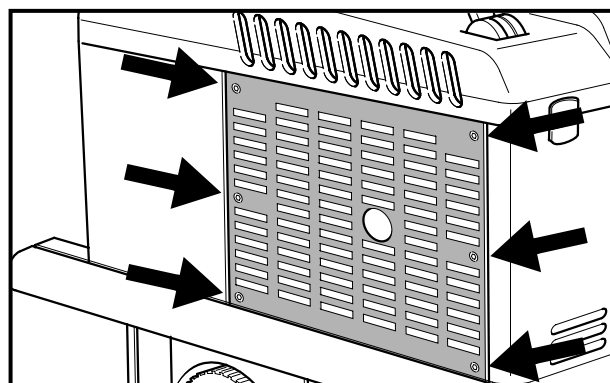
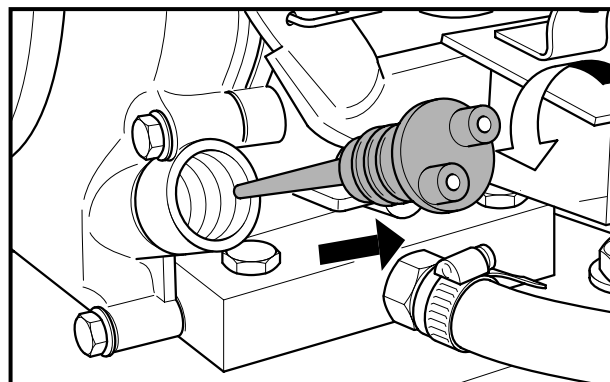

Remove the cap from the engine oil emptying hose and let the oil come out.

Note: it is suggested to remove the oil when the engine is warm.

Dispose of the used oil in proper special containers.

Note: keep the emptying hose lifted and open during filling.

Take a funnel and pour in the new oil (type indicated in the engine Use e Maintenance booklet) from the hose of the rod for oil level check. Fit the rod for oil level check and close the emptying hose with its cap.

At the end of the filling sequence check the engine oil level.

Make a periodic check of the engine air filter.

If necessary wash the engine air pre- filter (A) with water and soap or any other detergent for domestic use.

Squeeze it and dry it well.

Proceed by cleaning the filter B with compressed air (pressure not higher than 6 bar).

If the filter can't be completely cleaned, replace it.

Fit the engine air filter in its compartment and the relevant cover.

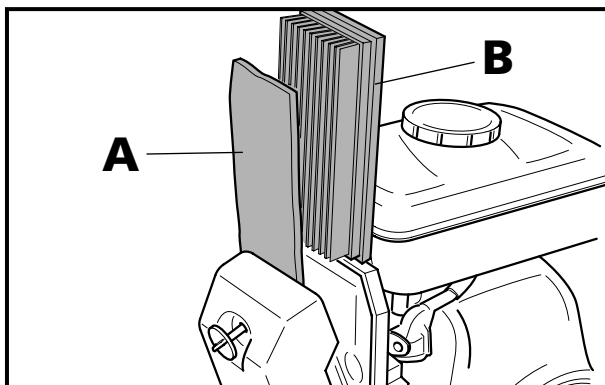
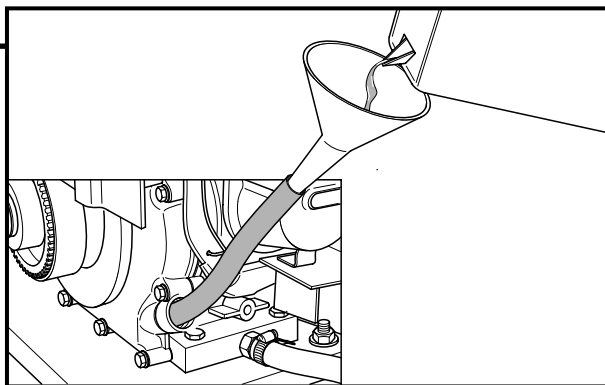

Warning: the following interventions must be done with machine in Off condition and master key out. All the periodic maintenance operations must be performed by skilled personnel or by an authorized service centre.

Note: the battery life will depend on a good periodic maintenance (check of the level of the electrolyte and of battery voltage). Besides it must be taken into account that an unused battery is submitted to a self-discharge phenomenon. In the event that the machine is not used for a long time (e.g. 3 or 4 weeks) it is necessary TO RECHARGE THE BATTERY; in fact the battery voltage MUST NEVER drop down below 20 Volt.

CONTROL	UPON DELIVERY	EVERY 30 HOURS	EVERY 50 HOURS	EVERY 100 HOURS	EVERY 400 HOURS
Battery liquid level and voltage check	●	● OR EVERY TWO WEEKS			
Check the carbon brushes of all electrical motors and replace them if worn					●
Belt tension	●			●	
Brake adjustment	●			●	
Filter shaker			●		
Nut and screw tightness				●	
Wear of main brush and side brushes			●		
Panel filter cleaning			●		
Sealing of gaskets of filter compartment and of flaps	●		●		
Clean the steering chain and (SR 1200 - SR 5120 only) the traction wheels chains with gas-oil or a proper solvent.				●	

**SUMMARY OF MAINTENANCE
CONTROLS (petrol version)**

S31NUK5120(3)2001-04

Warning: the following interventions must be done with machine in Off condition and master key out. All the periodic maintenance operations must be performed by skilled personnel or by an authorized service centre.

Every maintenance intervention on the petrol engine must be performed in agreement with the engine User Manual.

Note: the battery life will depend on a good periodic maintenance (check of the level of the electrolyte and of battery voltage). Besides it must be taken into account that an unused battery is submitted to a self-discharge phenomenon. In the event that the machine is not used for a long time (e.g. 3 or 4 weeks) it is necessary TO RECHARGE THE BATTERY; infact the battery voltage MUST NEVER drop down below 20 Volt.

CONTROL	UPON DELIVERY	TWO TIMES PER WEEK	ONE TIME PER WEEK	EVERY 20 HOURS	EVERY 50 HOURS	EVERY 100 HOURS	EVERY 400 HOURS
Battery liquid level and voltage check	●		●				
Engine air filter cleaning				●			
Panel filter cleaning					●		
Engine oil level check	1 st TIME	●					
Engine oil replacement				● (+) 1 st TIME		● (++)	
Engine RPM check and adjustment (*)						●	
Check the carbon brushes of all electrical motors and replace them if worn							●
Belt tension	●					●	
Brake adjustment	●					●	
Filter shaker					●		
Nut and screw tightness						●	
Wear of main brush and side brushes					●		
Sealing of gaskets of filter compartment and of flaps	●				●		
Clean the steering chain and (SR 1200 - SR 5120 only) the traction wheels chains with gas-oil or a proper solvent.						●	

For SR1100: 3200 engine shaft RPM with no function working and battery voltage higher than 27 Volt

For SR 1200: 3300 engine shaft RPM with no function working and battery voltage higher than 27 Volt

(+) 20 hours or not more than 1 month

(++) 100 hours or not more than 8 months

High capacity batteries both for the petrol version and for the battery version.

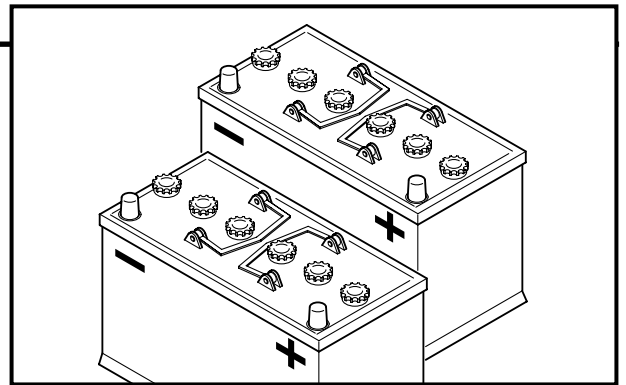

Battery charger

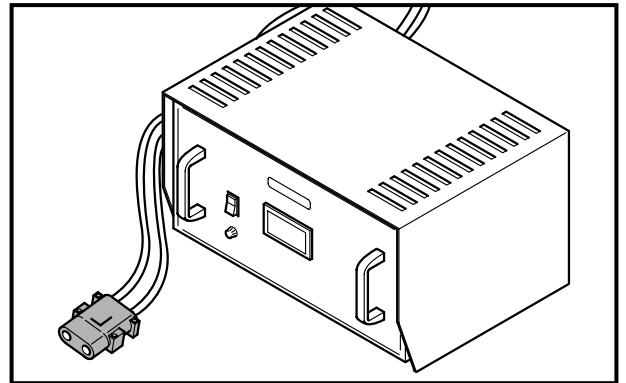

Different types of main brushes and side brushes

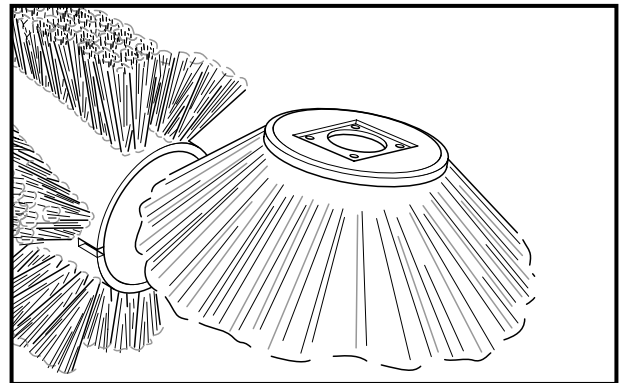

Polyester panel filter (it can be washed)

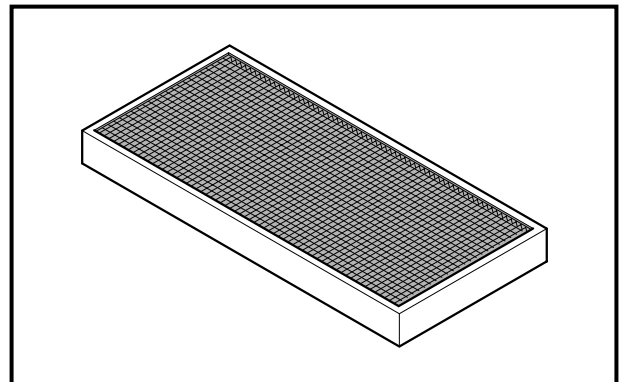

- Mini containers
- Flashing beacon on support
- Rollbar
- Flashing beacon on rollbar
- Front rollers and side bumpers
- Non marking wheels

For further information on all accessories get in touch with your supplier

The machine is equipped with many safety devices and functions which have been described in the USE paragraphs (both for petrol and electrical versions). For instance the automatic stop of all functions to avoid the deep discharge of the battery has been mentioned; and also the availability of a special red key for the disengagement of the self-breaking function has been notified: this is to be operated when the machine must be pushed in Off condition.

Besides the intervention of other safety functions is notified by means of dedicated safety codes appearing on the display. These safety codes are described in the following table.

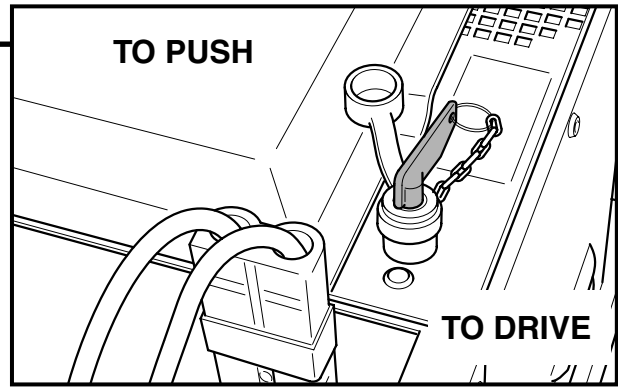

SEE SAFETY CODE 333

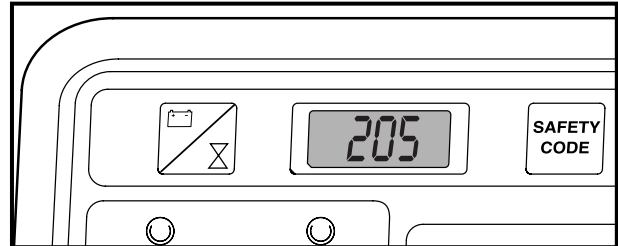

SAFETY CODE	MACHINE BEHAVIOUR	DESCRIPTION OF THE MALFUNCTION	POSSIBLE INTERVENTION
205	Stop of all functions except traction	The battery is empty	Recharge the battery according to the instructions given in the Maintenance paragraph
301	Stop of all functions and traction	Overtemperature of the drive motor	-If the machine run on a long ramp it could be normal: let the machine cooling 20 minutes -Check the efficiency of the front and rear brakes -Check the rotation of the rear drive wheels
302	The machine does not start or, in the event it was working, will stop	Possible problem with traction control electronic circuit	-Check carbon brushes of traction motor -Check connection cables of traction motor -If the above is OK replace the power electronic board
305	The machine functions will stop	High temperature on the electronic control circuits (95 °C)	-If the ambient temperature is high let the machine cool down 20 minutes -If the problem will remain call the technical service to check the electrical motors
306	Stop of all functions and traction	High temperature on the electronic control circuits (105 °C)	-Make the same checks as per code 305
307	The machine does not start	Wrong start sequence	-Release the accelerator pedal before turning the key On
308	The machine does not start	Damage of the cable of potentiometer for traction control	-Check the cable connections of the potentiometer for traction control - Check the potentiometer for traction control
333	The machine does not start	-Off status of the red key for the disabling of the self braking function (see the picture on the top page) -Possible trouble of motor cables (short circuit or open circuit)	-Insert the red key and turn it clockwise -Check the motor cables
800	Display flashing	Main brush worn	-Replace the main brush
E10	Flashing display	Main broom is blocked	Remove the main broom and clean all dirty parts

AUSTRALIA

Nilfisk-Advance Pty. Ltd.
ACN 003 762 623
Head office: 17 Leeds Street, Rhodes, N. S. W. 2138
Tel.(02) 9736 1244 - Fax (02) 9736 3910
Customer Response Centre:
Tel.1 800 011 013

BELGIQUE/BELGIË/LUXEMBOURG

Nilfisk-Advance s.a./n.v.
Doornveld/Sphere Business Park
Industrie Asse 3, nr 11- bus 41
1731 Zellik-Asse
Tel.(02) 467.60.50 Fax (02) 463.44.16

CANADA

Nilfisk-Advance Ltd
396 Watline Avenue
Mississauga, Ontario L4Z 1X
Tel.(905) 712-3260 - Fax (905) 712-3255

DANMARK

Nilfisk-Advance Nordic A/S
Myntevej 3, 8900 Randers
Tel.86 42 84 33 - Fax 86 41 19 55

DEUTSCHLAND

Nilfisk-Advance AG
Siemensstraße 25-27
25462 Rellingen
Tel.(04101) 3990 - Fax (04101) 399191

Zentraler Kundenservice / Customer Hotline
Tel.0180 53 56 797

ESPAÑA

Nilfisk-Advance, S.A.
Torre D'Ara
Passeig del Rengle, 5 -PI.10
E-08302 Mataró (Barcelona)
Spain
Tel.: 93 741 2400
Fax: 93 757 8020
nilfisk@nilfisk-advance.es
Teléfono nacional de servicio Comercial: 902 200 201
Teléfono nacional de servicio Técnico: 902 300 301
Delegaciones, Distribuidores y Servicio Técnico a domicilio en todas las regiones de España.

FINLAND/ SUOMI

Oy Tecalemit AB
Hankasuontie 13, 00390 Helsinki
Tel.(89) 547 701- Fax (89) 547 1779

FRANCE

Nilfisk-Advance S.A
BP 246
91944 Courtaboeuf Cedex
Tel.(01) 69.59.87.00 Télécopie (01) 69.59.87.01

PORTUGAL

Nilfisk-Advance Lda.
Rua Cândido de Figueiredo, 91-i, 1500-133 LISBOA
Tel.01/7784142-Fax01/7785613
Porto 02/526766 - Fax 02/520739
Açores 096/628092/3 - Fax 096/628129
Madeira 091/228965 - Fax 091/228796

SCHWEIZ / SUISSE

Nilfisk-Advance AG
Ringstrasse 19, 9533 Kirchberg/Wil
Tel.719 23 52 83 - Fax 719 23 84 44

SINGAPORE

Nilfisk-Advance Pte. Ltd.
10, Woodlands Loop
Singapore 738388
Tel.(65) 759 9100 - Fax (65) 759 9133

SVERIGE

Nilfisk-Advance AB
Sjöbjörnsvägen 5, 117 67 Stockholm
Tel.085 55 944 00 - Fax 085 55 944 30

TAIWAN

Nilfisk-Advance Ltd
1 F, No.23, Lane 132, Sec. 2
Ta An Road, Taipei

Tel.700 22 68 - Fax 784 08 43

UNITED KINGDOM

Nilfisk-Advance Limited
Newmarket Road
Bury St. Edmunds
Suffolk IP 33 3SR
Tel.(01284) 763163 - Fax (01284) 750562

USA

Nilfisk-Advance Inc.
14600 21st Avenue North
Plymouth, MN 55447-3408
Tel. +1763 475 2235 - Fax 1763 473 1764

Nilfisk-Advance of America, Inc.
300 Technology Drive
Malvern, PA 19355
Tel.(610) 647 6427

ÖSTERREICH

Nilfisk-Advance GmbH
Vorarlberg Allee 46
1230 Wien
Tel.1616 58 30 - Fax 1616 58 30 40

HONG KONG

Nilfisk-Advance Ltd
2001, 20/F HK Worsted Mills
Industrial Building
31-39 Wo Tong Tsui Street
Kwai Chung, N.T.
Tel.2427 59 51- Fax 2487 5828

IRELAND

Nilfisk-Advance Ltd
28 Sandyford Office Park
Dublin 18
Tel. +353 12943838 - Fax +353 12943845

ITALIA

Nilfisk-Advance Italia SPA
Località Novella Terza
26862 Guardamiglio (LO) I
Tel. + 39 (0377) 451124 - Fax + 39 (0377) 51443

JAPAN

Nilfisk-Advance Inc.
3-4-9 Chigasaki Minami
Tsunami-Ku Yokohama 224
Tel.045-942-7741- Fax 045-942-6545

MALAYSIA

Nilfisk-Advance Sdn Bhd
Lot 2, 1st. Floor
Lorong 19/1A
46300 Petaling Jaya
Selangor Darul Ehsan
Tel.03-7568188/03-7568189/03-7568388-Fax03-7566828

NEDERLAND

Nilfisk-Advance B.V.
Flevolaan 7, Postbus 341
1380 AH Weesp
Tel.0294-462121- Fax 0294-430053

NEW ZEALAND

Nilfisk-Advance Limited
477 Great South Road, Penrose
Auckland
Tel.(09) 525 0092 - Fax (09) 525 6440

NORGE

Nilfisk-Advance AS
Enebakkvn, 119, 0680 Oslo, Postboks 196, Manglerud, 0612 Oslo
Tel.22 08 63 50 - Fax 22 08 63 63
Distriktsrepresentanter over hele landet



Nilfisk-Advance Italia S.p.A

Località Novella Terza
26862 Guardamiglio (Lodi) Italia
www.nilfisk-advance.com
Phone: +39 0377 451124
Fax: +39 0377 51443
Printed in Italy